

NOTE THIS DRAWING IS FOR GUIDANCE ONLY AND MUST NOT BE USED AS A PROPER WORKING DRAWING. FOR ENQUIRIES ABOUT THE LIFT PLEASE CONTACT THE **Platform Lift Co** - TEL 01256 896000

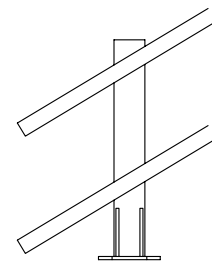

Optional Stanchion Mounted Rail

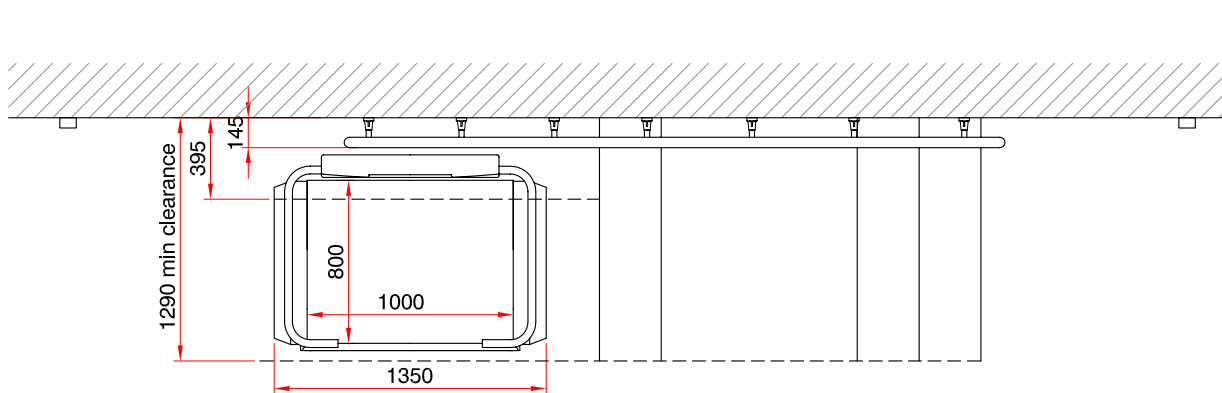
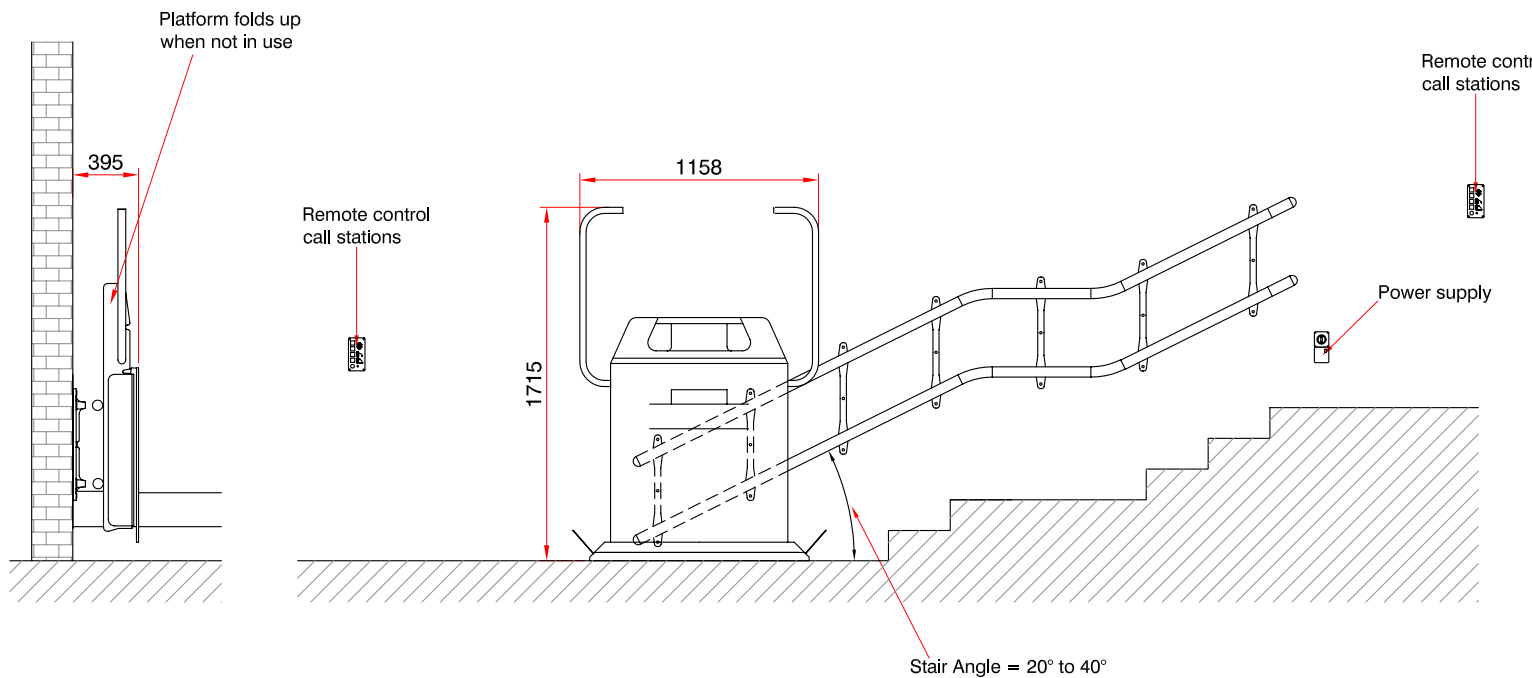

Stairiser Platform Specification

- Load: 230kg / 1 wheelchair
- Drive: Rack and Pinion
- Speed: 0.01m / sec
- Travel: subject to survey
- Stops: 2
- Motor: 1.1kw
- Power: 240v 1ph 50Hz 10A
- Colour: RAL 7035 as standard (alternative RAL colours available)

Note - Platform carriage available as a left hand or right hand unit

Platform Lift Company
 Apsley Barns, Apsley, Near Andover, Hants, SP11 6NA
 Tel - 01256 896000
 Fax - 01256 896900
 E-mail - info@platformliftco.co.uk
 website - www.platformliftco.co.uk

TITLE		C6 - Curved Stairiser	
DWG NO.		230 - C6 - ELEV	REV A
SCALE	NTS	DATE	28/09/06
DRAWN		RH	